

# DOUBLE CHAINSTITCH MACHINE

**VC008A**

-

**04**

**064**

**P**

/

**VCE**

針數  
Needle Numbers

後拉引滾輪  
Rear Pullers

配件  
Device

## 機種別 Model

VC008A 筒型多針縫紉機(高貫穿力型)  
Multineedle Cylinder Bed Double Chainstitch  
Machine (High Penetration Power Type)

VC008B 筒型多針縫紉機(4~6針高速型)  
Multineedle Cylinder Bed Double Chainstitch  
Machine (4~6 Needles High Speed Type)

HF008A 平台型牛仔用二重環縫紉機  
Flat Bed Double Chainstitch Machine for  
Jeans

NC008 針送牛仔褲腰車  
Needle-Feed Cylinder Bed Double  
Chainstitch Machine for Jeans Waistband

## 等距針距

Equal Distance Between Needles

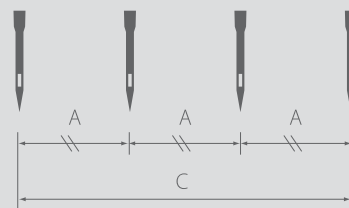

## 不等距

Unequal Distance Between Needles

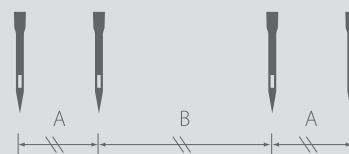

# DOUBLE CHAINSTITCH DD SERVO MOTOR

**VC008A**

-

**04085P**

**/ VWLB**

**/ FH**

**/ DV□□**

DV□□ VC008A/B, HF008A, NC008型直驅電控組  
Direct Drive Servo Motor for VC008A/B, HF008A,  
NC008

# VC008A / B SERIES FEATURES



## VC008A

筒型多針縫紉機(高貫穿力型)

**Multineedle Cylinder Bed Double Chainstitch Machine (High Penetration Power Type)**



完全自動供油，勾針縱向運動機構，多針雙重鏈式縫

Automatic lubrication system, vertical looper mechanism, multineedle chainstitch mechanism.



採用獨立勾針座，可變化不同的針位元組合，達到一機多用的功能（選配）

Using independent looper holder and can easily change different needle position, Multi-function machine design.(optional)



筒型機身設計，方便環型衣物縫紉

Cylinder machine frame design, easy sewing operation for circular cloth.



按鈕式縫距調整模式，調整簡便快速

Stitch length adjustment by knob, easy and fast.



左側附一輔助設計，拉布穩定，出布更順暢，維護便利

Using one supportive puller on left side which can stabilize the pulling and sewing process.



適用於多種工序的縫紉，適合針織類高級衣物之裝飾車縫

Suitable for multi sewing process, high quality knit material and decorative sewing.



新型軸承式滾輪，縫製時拉布與出布更順暢穩定

New bearing type rear puller handles the material with better stability.

## VC008B

筒型多針縫紉機 (4~6針高速型)

**Multineedle Cylinder Bed Double Chainstitch Machine (4~6 Needles High Speed Type)**

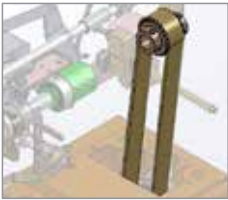

使用皮帶傳動來驅動上下軸，實現高速穩定的縫製

New mechanism uses the belt to drive both upper and lower shaft, provides faster and more stable sewing experience.



平順且低振動，車縫薄料得心應手

High performance with thin material, less vibration and smoother movement.









新型軸承式滾輪，縫製時拉布與出布更順暢穩定

New bearing type rear puller handles the material with better stability.





V3

							Needle No.	
VC008A- VC008B-	04064P/VCE	4	8	1/4"(6.4mm)	1.4~3.6	12	UOX113GS #11~#14	4000
	04085P/VCE	4	8	1/3"(8.5mm)	1.4~3.6	12	UOX113GS #11~#14	4000
	04095P/VCE	4	8	3/8"(9.5mm)	1.4~3.6	12	UOX113GS #11~#14	4000
	04106P/VCE	4	8	5/12"(10.6mm)	1.4~3.6	12	UOX113GS #11~#14	4000
	04127P/VCE	4	8	1/2"(12.7mm)	1.4~3.6	12	UOX113GS #11~#14	4000



VC008B-04064P/VCE

**褲頭鬆緊帶車縫**

用於運動褲或運動短褲等圓筒型衣褲腰部鬆緊帶的包縫。本機型可有兩種縫合的方式：  
(1)環型鬆緊帶布料折邊縫 (2)拷克後上環型鬆緊帶包縫

**ELASTIC INSERTING / ATTACHING**





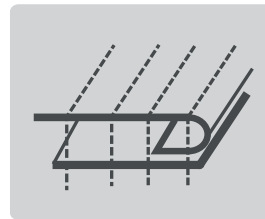
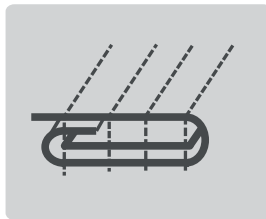

Inserting and attaching elastic on waistband of jogging suits, sportswears or shirts etc., two types of sewing functions are available :

1. To attach tubular seamless elastic waistband.
2. To cover sewing on elastic after overlock seaming.

選購配件	OPTIONAL DEVICE
	VAD , RL



V4

							Needle No.	
VC008A-	04064P/VWL	4	8	1/4"(6.4mm)	1.4~3.6	12	UOX113GS #11~#14	4000
	04085P/VWL	4	8	1/3"(8.5mm)	1.4~3.6	12	UOX113GS #11~#14	4000
	04095P/VWL	4	8	3/8"(9.5mm)	1.4~3.6	12	UOX113GS #11~#14	4000
	04106P/VWL	4	8	5/12"(10.6mm)	1.4~3.6	12	UOX113GS #11~#14	4000
	04127P/VWL	4	8	1/2"(12.7mm)	1.4~3.6	12	UOX113GS #11~#14	4000

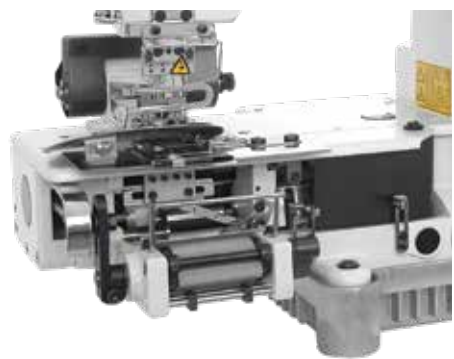

VC008A-04085P/VWL

**褲頭鬆緊帶車縫 (附B413喇叭)**

鬆緊帶送帶滾輪裝置能依據機台之運轉速度送帶，可準確控制鬆緊帶長度與鬆緊度。操作簡便，適用於慢跑褲、運動褲、男女內褲等褲頭之鬆緊帶車縫。

註：B413喇叭可用鬆緊帶尺寸為 38mm

**ELASTIC ATTACHING (WITH FOLDER B413)**





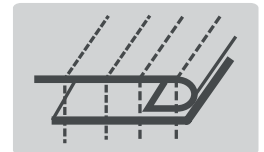

Elasticity and length feeding can be accurately controlled according to sewing speed of machine. Easy operation for elastic inserting and attaching on waistband of jogging pants, sportswears, briefs etc.

Remark : Elastic size 38mm for folder B413



選購配件	OPTIONAL DEVICE
	FH

# V5

							Needle No.	
VC008A-	04064P/VWLB	4	8	1/4"(6.4mm)	1.4~3.6	12	UOX113GS #11~#14	4000
	04085P/VWLB	4	8	1/3"(8.5mm)	1.4~3.6	12	UOX113GS #11~#14	4000
	04095P/VWLB	4	8	3/8"(9.5mm)	1.4~3.6	12	UOX113GS #11~#14	4000
	04106P/VWLB	4	8	5/12"(10.6mm)	1.4~3.6	12	UOX113GS #11~#14	4000
	04127P/VWLB	4	8	1/2"(12.7mm)	1.4~3.6	12	UOX113GS #11~#14	4000

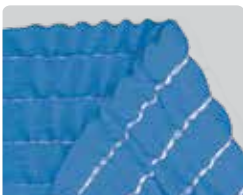
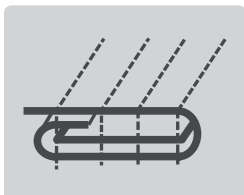

## 褲頭鬆緊帶車縫 (附B411喇叭及撐開滾輪組)

鬆緊帶送帶滾輪裝置能依據機台之運轉速度送帶，可準確控制鬆緊帶長度與鬆緊度，操作簡便，適用於慢跑褲、運動褲、男女內褲等褲頭之鬆緊帶車縫。







## ELASTIC INSERTING (WITH FOLDER B411 AND EXTENDING ROLLER)

Elasticity and length feeding can be accurately controlled according to sewing speed of machine. Easy operation for elastic inserting and attaching on waistband of jogging pants, sportswears, briefs etc.

喇叭尺寸 Folder Size	成品尺寸 Finished Size	鬆緊帶尺寸 Elastic Tape Size	適用機型 Applicable Model
B411	33 mm	31 mm	04095
B411P	30 mm	28 mm	04085
B411Q	42 mm	40 mm	04127
B411R	25 mm	23 mm	04064
B411S	36 mm	34 mm	04106

選購配件 OPTIONAL DEVICE
FH

# V6

							Needle No.	
VC008A-	04064P/VWLC	4	8	1/4"(6.4mm)	1.4~3.6	12	UOX113GS #11~#14	4000
	04085P/VWLC	4	8	1/3"(8.5mm)	1.4~3.6	12	UOX113GS #11~#14	4000
	04095P/VWLC	4	8	3/8"(9.5mm)	1.4~3.6	12	UOX113GS #11~#14	4000
	04106P/VWLC	4	8	5/12"(10.6mm)	1.4~3.6	12	UOX113GS #11~#14	4000
	04127P/VWLC	4	8	1/2"(12.7mm)	1.4~3.6	12	UOX113GS #11~#14	4000
	12048P/VWLC	12	24	3/16"(4.8mm)	1.4~3.6	12	UOX113GS #11~#14	4000
	12064P/VWLC	12	24	1/4"(6.4mm)	1.4~3.6	12	UOX113GS #11~#14	4000

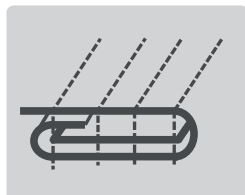

## 褲頭鬆緊帶車縫 (附VCE導片)

鬆緊帶送帶滾輪裝置能依據機台之運轉速度送帶，可準確控制鬆緊帶長度與鬆緊度，操作簡便，適用於慢跑褲、運動褲、男女內褲等褲頭之鬆緊帶車縫。





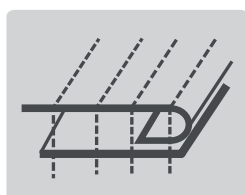

## ELASTIC INSERTING /ATTACHING (WITH VCE FABRIC GUIDE)

Elasticity and length feeding can be accurately controlled according to sewing speed of machine. Easy operation for elastic inserting and attaching on waistband of jogging pants, sportswears, briefs etc.



選購配件 OPTIONAL DEVICE
FH

# V7

							Needle No.	
VC008A-	06048P/VPL	6	12	3/16"(4.8mm)	1.4~3.6	12	UOX113GS #11~#14	4000
VC008B-	06064P/VPL	6	12	1/4"(6.4mm)	1.4~3.6	12	UOX113GS #11~#14	4000



VC008B-06064P/VPL

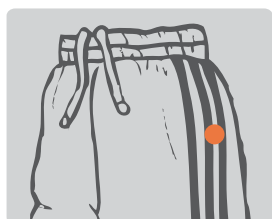

## 上帶車縫

適用於裝飾條帶、運動衣褲等車縫，效率高、品質穩定。

## TAPE ATTACHING

Suitable for attaching ornament tape on sportswears.  
For high efficiency and perfect quality sewing.





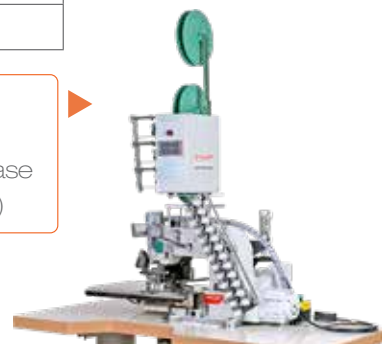

選購配件 OPTIONAL DEVICE

LSA

若需要更高階機型，請參考  
ASV-ATS100A (P.16)  
For advanced model, please  
refer to ASV-ATS100 (P.16)



# V8

							Needle No.	
VC008A-	12048P/VPQ	12	24	3/16"(4.8mm)	1.4~3.6	12	UOX113GS #11~#14	4000
	12064P/VPQ	12	24	1/4"(6.4mm)	1.4~3.6	12	UOX113GS #11~#14	4000



VC008A-12064P/VPQ

## 鬆緊帶抽皺縫裝置

適用於女皺折連身衣裙等腰邊鬆緊線皺折，如女用襯衫、游泳衣、枕頭套、兒童衫等  
均能車縫順暢。

注：勾針底線宜用彈性線

## ELASTIC THREAD SHIRRING SEWING





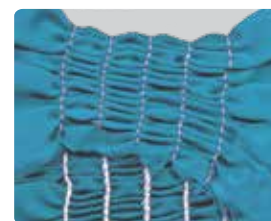
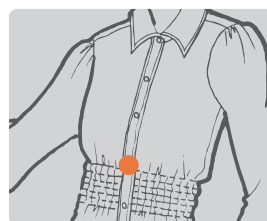

Suitable for sewing ornamental shirring with elastic thread on women's blouses, swimsuits, dresses, pillowcases, and children's shirts etc.

Remark : Suggested to use elastic thread for lower looper





# V9

							Needle No.	
VC008A-	12048P/VPQ-K	12	24	3/16"(4.8mm)	1.4~3.6	12	UOX113GS #11~#14	4000
	12064P/VPQ-K	12	24	1/4"(6.4mm)	1.4~3.6	12	UOX113GS #11~#14	4000



VC008A-12048P/VPQ-K

## 鬆緊帶抽皺縫裝置

適用於女皺褶連身衣裙等腰邊鬆緊線皺褶，如女用襯衫、游泳衣、枕頭套、兒童衫等均能車縫順暢。

註：

1. 勾針底線宜用彈性線。
2. 增加VWL組可穩定彈性線的鬆緊度讓車縫更平順美觀，不跳針。
3. 將彈性線安裝於桌板下，讓彈性線車縫更順暢。
4. 本機為多功能車，可調為VWL、VPQ或一般車使用。

## ELASTIC THREAD SHIRRING SEWING





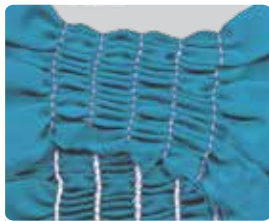
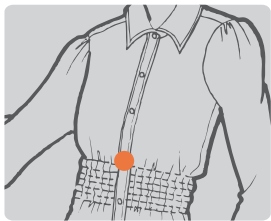

Suitable for sewing ornamental shirring with elastic thread on women's blouses, swimsuits, dresses, pillowcases, and children's shirts etc.

Remark :

1. Suggested to use elastic thread for lower looper.
2. The added VWL set will further stabilize the tension of elastic thread and make sewing process more smoothly, also can avoid stitch skipping.
3. Holds the elastic thread under the table to make sewing process more smoothly.
4. This is a multifunctional machine, can easily adjust to VWL, VPQ, or standard machine.



# V10

							Needle No.	
VC008A-	12048P/VPS	12	12	3/16"(4.8mm)	1.4~3.6	12	DV-K25 #18~21	4000
	12064P/VPS	12	12	1/4"(6.4mm)	1.4~3.6	12	DV-K25 #18~21	4000

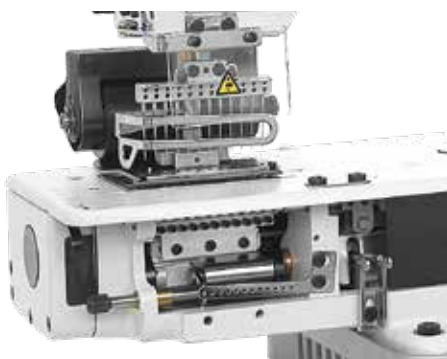

VC008A-12064P/VPS

## 鬆緊帶抽皺縫裝置

適用於女皺褶連身衣裙等腰邊鬆緊線皺褶，如女用襯衫、游泳衣、枕頭套、兒童衫等均能車縫順暢。





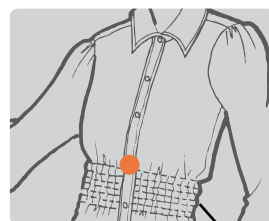

註：針線用彈性線，以勾針為勾線功能不穿線，為101車縫式樣

## ELASTIC THREAD SHIRRING SEWING

Suitable for sewing ornamental shirring with elastic thread on women's blouses, swimsuits, dresses, pillowcases, and children's shirts etc.

Remark : Needle uses elastic thread and looper without thread. It's 101 sewing type.



				 mm	 mm	 mm	 Needle No.	 S.P.M. (Max)
VC008A-	12048P/VSC	12	36	3/16"(4.8mm)	1.4~3.6	12	UOX113GS #11~#14	2500
	12064P/VSC	12	36	1/4"(6.4mm)	1.4~3.6	12	UOX113GS #11~#14	2500

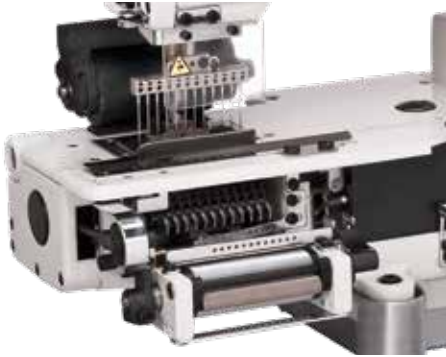

VC008A-12064P/VSC

### 鬆緊帶抽皺縫裝置

彈性線直送不打線圈，由針線與勾針線上下包覆，車縫成品效果較VPQ薄，且皺褶可拉伸至完全平坦。

### ELASTIC THREAD SHIRRING SEWING

Elastic thread is straight, not looped, which is fixed by needle thread and looper thread. The finish is thinner than VPQ and the shirring becomes flat as it is pulled extensively.

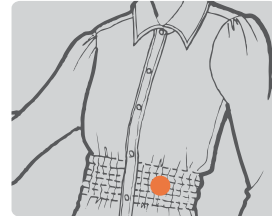

# HF008A SERIES FEATURES

## HF008A

### 平台型牛仔用二重環縫紉機 Flat Bed Double Chainstitch Machine for Jeans



精心設計之供油系統及零配件精度加工，延長機器使用壽命

Using unique design of lubrication system and attachments to extend the machine lifetime.



按鈕式縫距調節可適合多品種生產

Stitch length adjustment by knob, suitable for all different kinds of materials.



上下滾輪之雙重配合使出布更順暢

Upper and lower puller design to make sewing process more stable.

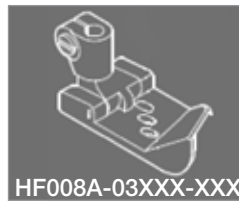

HF008A-03XXX-XXX

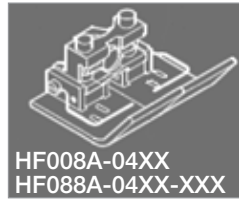
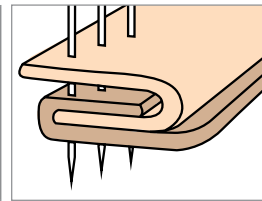

HF008A-04XX  
HF088A-04XX-XXX

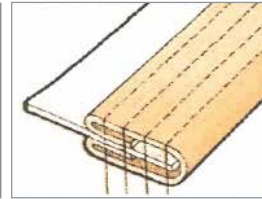

適用工作服、牛仔褲之搭縫(埋夾縫)與褲頭車縫

Suitable for tape binding on waistband of workwear pants, jeans.

## H1

			mm	mm	mm	mm	mm	Needle No.
HF008A-02064P/HHD	2	4	1/4"(6.4mm)	1.8~3.6	12	UYX128GAS#14~#16	4200	
HF008A-03064P/HHD	3	6	1/4"(6.4mm)	1.8~3.6	12	UYX128GAS#14~#16	4200	



HF008A-02064P/HHD

### 埋夾縫

適用於薄至厚料如工作服、牛仔褲之搭縫。

註：一般出車，均不附喇叭，如有需要可依以上規格訂製

### LAP SEAMING

To lap seaming on light to heavy material such as workweares or jeans, etc...

Remark : Folder is not included. Please specify folder no. when ordering.

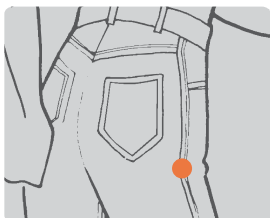

可選擇之規格 Available Model		布料 Material	喇叭代號 Folder No.
02064/HHD 03064/HHD	1/4"	薄料 light	B511
		中厚料 medium	B511P
		厚料 heavy	B511Q

# H2

HF008A-03064P/HTF	3	6	1/4"(6.4mm)	1.8~3.6	12	TVX5 #18~#21	4200
-------------------	---	---	-------------	---------	----	--------------	------



HF008A-03064P/HTF

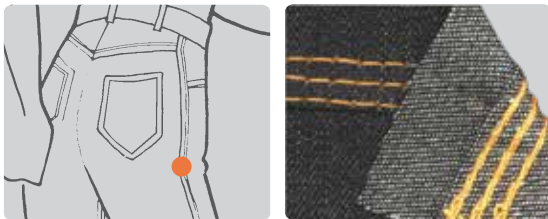

## 搭縫

適用於中厚布料至極厚布料如工作服、牛仔褲等粗斜紋布之搭縫用。  
註：一般出車，均不附喇叭，如有需要可依以上規格訂製

## LAP SEAMING

To lap seaming on medium to extra heavy material such as workwears or jeans, etc...

Remark : Folder is not included. Please specify folder no. when ordering.

布料 Material	喇叭代號 Folder No.
中厚料 Medium	B511P
厚料 Heavy	B511Q
極厚料 Extra Heavy	B511R

# H3

HF008A-0464-254P/HPR	4	8	1/4-1-1/4" (6.4-25.4-6.4mm)	1.4~3.6	12	TVX5 #18~#21	4500
HF008A-0664-254P/HPR	4 (6)	8	1/8-1/8-1-1/8-1/8" (3.2-3.2-25.4-3.2-3.2mm)	1.4~3.6	12	TVX5 #18~#21	4500



HF008A-0664-254P/HPR/B530



HF008A-0464-254P/HPR

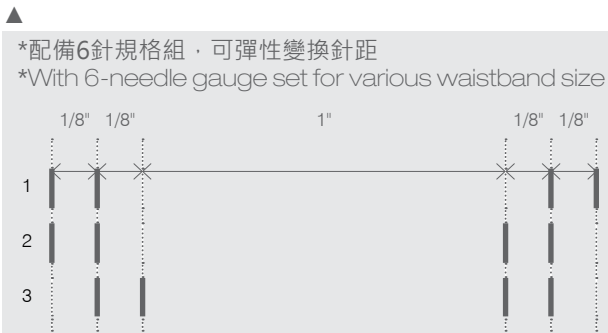
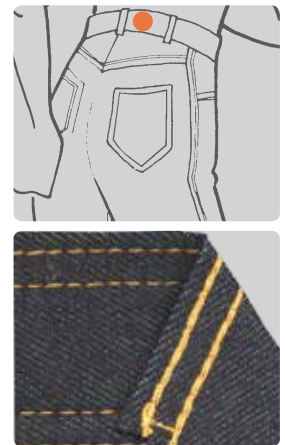

選購配件 OPTIONAL DEVICE
FH

## 褲頭上帶滾邊車縫

適用於厚料之工作褲、牛仔褲等褲頭之上帶滾邊一次成型車縫，可依布條之縫合樣式選擇喇叭。

註：一般出車，均不附喇叭，如有需要可依以上規格訂製



## WAISTBAND ATTACHING

For tape binding on waistband of workwears pants, jeans...etc. Refer to below table to find optional binders for desirable seams.





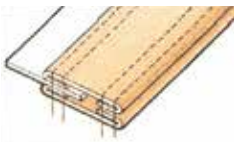
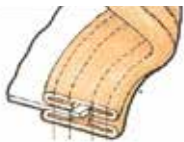

Remark : Binder is not included. Please specify binder no. when ordering.

# H3

## 選配喇叭 OPTIONAL BINDER

成品尺寸 (Finished Size)	上下片直送 For Continuous Strips	上下片弧形 For Arched Type	側送喇叭 Side Feeding	前送喇叭 Front Feeding
1" (25mm)	-	-	-	B530
1- 1/8" (29mm)	-	-	-	B530P
1- 1/4" (32mm)	B516	B518	B519	B530Q
1- 3/8" (36mm)	B516P	B518P	B519P	B530R
1- 1/2" (38mm)	B516Q	B518Q	B519Q	B530S
1- 5/8" (42mm)	B516R	B518R	B519R	B530T
1- 3/4" (45mm)	B516S	B518S	B519S	B530U
縫合樣式 Seam Type				

# H4

							
	mm	mm	mm	mm	Needle No.	S.P.M. (Max)	
HF008A-0464-254P/PMP	4	8	1/4-1-1/4" (6.4-25.4-6.4mm)	1.4~3.6	12	TVX5 #18~#21	4500
HF008A-0664-254P/PMP	4 (6)	8	1/8-1/8-1-1/8-1/8" (3.2-3.2-25.4-3.2-3.2mm)	1.4~3.6	12	TVX5 #18~#21	4500



HF008A-0664-254P/PMP/  
B530

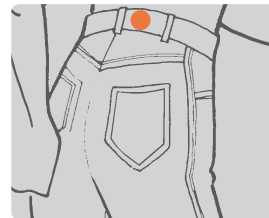







### (可調整角度)褲頭上帶滾邊車縫

同HPR褲頭上帶滾邊車縫功能，但角度可進行調整；適用於有曲度之褲腰車縫。

### (ANGLE-ADJUSTABLE) WAISTBAND ATTACHING

Same waistband attaching function as HPR, with adjustable angle to process curved workpieces.

# H5

							
			mm	mm	mm	Needle No.	S.P.M. (Max)
HF008A-02056P/FBQ	2	3	7/32"(5.6mm)	1.8~3.6	12	UYX128GAS#10~#11	4200
HF008A-02064P/FBQ	2	3	1/4"(6.4mm)	1.8~3.6	12	UYX128GAS#14~#16	4200

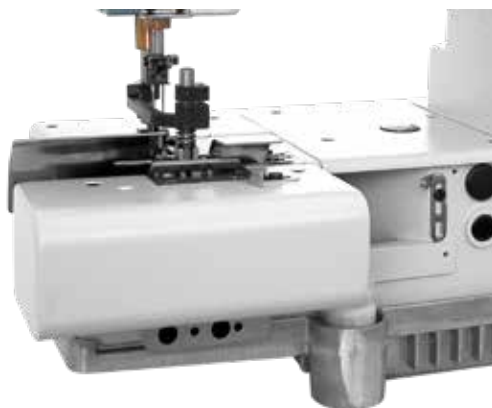

HF008A-02064P/FBQ

## 褲耳車縫 (附雙邊切刀)

用本輔助件雙邊切刀裁布之功能，可將零碎之廢布利用來製作褲耳，減少布料消耗。





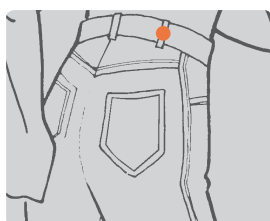

## BELT-LOOP SEAMING (WITH RIGHT & LEFT FABRIC TRIMMER)

This machine is equipped with an adjustable fabric trimmer to cut excess fabric edge neatly, and seaming to belt loops for saving cost and increase efficiency.



可選擇之規格 Available Model	成品尺寸 Finished Size	喇叭代號 Folder No.	適用 Application
HF008A-02056P/FBQ	9 mm	FBQ14A	男女西褲 Trousers
	10 mm	FBQ14B	
HF008A-02064P/FBQ	12 mm	FBQ14C	牛仔布 Jeans

# H6

							
			mm	mm	mm	Needle No.	S.P.M. (Max)
HF008A-0464-254P/PMP/JD	4	8	1/4-1-1/4" (6.4-25.4-6.4mm)	1.4~3.6	12	TVX5 #18~#21	4500
HF008A-0664-254P/PMP/JD	4 (6)	8	1/8-1/8-1-1/8-1/8" (3.2-3.2-25.4-3.2-3.2mm)	1.4~3.6	12	TVX5 #18~#21	4500



HF008A-0664-254P/PMP/JD



## 牛仔褲腰車縫 (自動跳針)

車縫褲腰時可使用自動跳針功能避開不需縫製的地方。

## JEANS WAISTBAND ATTACHING (WITH SKIP-STITCH FUNCTION)

When sewing waistband at the opening area, skip-stitch function can save your time of cutting the seam.

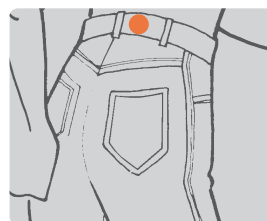

# NC008 SERIES FEATURES

## NC008

### 針送牛仔褲腰車

### Needle Feed Cylinder Bed Double Chainstitch Machine for Jeans Waistband



後拉輪能在高速車縫時讓送布均勻，線跡美觀

Rear puller allows stable material feeding and well-balanced seam.



可同步調整線跡長度與送布量的針送+下送送布機構

Needle feed and material feed can be adjusted synchronously.



可對應至16oz的丹寧布等重厚型布料

Work on heavy material like Denim, up to 16 oz.



最適合車縫牛仔褲腰，也可應用於牛仔褲的約克、捲邊縫、門襟車縫，上鬆緊帶

Designed for jeans waistband sewing, also can apply on jeans yoke seam, front, and elastic attaching.



## 配件 / DEVICE



### HPR / 褲頭上帶滾邊車縫

適用於厚料工作褲・牛仔褲的上帶滾邊一次成型車縫  
左右分開的下輪可用轉彎縫製，可依樣式選擇喇叭。

### HPR/Waistband Attaching Device

For tape binding on waistband of workwears pants, jeans...etc.  
Refer to below table to find optional binders for desirable seams.



### JD / 跳針裝置

避開褲腰車縫時不需下針的地方。

### Skip Stitch Device

Control freely to avoid stitches sewed on un-wanted working area.

## 選配喇叭 / OPTIONAL BINDER

成品尺寸 (Finished Size)	上下片直送 For Continuous Strips	上下片弧形 For Arched Type	側送喇叭 Side Feeding	前送喇叭 Front Feeding
1- 3/8" (36mm)	B516P	B518P	B519P	B530R
1- 1/2" (38mm)	B516Q	B518Q	B519Q	B530S
1- 5/8" (42mm)	B516R	B518R	B519R	B530T
1- 3/4" (45mm)	B516S	B518S	B519S	B530U
縫合樣式 Seam Type				

## 規格 / SPECIFICATION

NCO08							
			mm	mm	mm	Needle No.	S.P.M. (Max)
<b>NC008-02318</b>	2	4	5/4" (31.75mm)	1.4~3.6	9	DXV57 #14~#25	4000
<b>NC008-02381</b>	2	4	3/2" (38.1mm)	1.4~3.6	9	DXV57 #14~#25	4000
<b>NC008-0464-254</b>	4	8	1/4-1-1/4" (6.4-25.4-6.4mm)	1.4~3.6	9	DXV57 #14~#25	4000
<b>NC008-04254</b>	4	8	1" (25.4mm)	1.4~3.6	9	DXV57 #14~#25	4000
<b>NC008-0464-254/HPR</b>	4	8	1/4-1-1/4" (6.4-25.4-6.4mm)	1.4~3.6	9	DXV57 #14~#25	4000
<b>NC008-0464-222/HPR</b>	4	8	1/4-7/8-1/4" (6.4-22.2-6.4mm)	1.4~3.6	9	DXV57 #14~#25	4000
<b>NC008-06064</b>	6	12	1/4" (6.4mm)	1.4~3.6	9	DXV57 #14~#25	4000



# PICOTING MACHINE

One / Two Needle Picoting Chainstitch Machine

**Z008 - 2 48 Q**

機種別 Model  
Z008 外曲牙縫紉機  
Picoting  
Chainstitch  
Machine

針數  
Needle numbers  
1  
2

針距  
Needle Gauge  
mm



Z008-248Q

代碼 Code	型式 Type	車縫導片 / 壓具 Guide / Presser Foot	車縫樣式 Sewing Pattern
Q	雙鋸齒型 Double-Picot	ZB11-A 	P7873-A 
		ZB09* 	P7872-A* 
		ZB09* 	P7872-A* 

\* 備註：置於配件盒當中  
\*Remark: Parts marked with an asterisk included in the accessory box.



獨特的筒型台面設計使車縫更得心順手，更適於筒狀物的車縫，整體的外觀設計使操作與技術者的維修更容易

Cylinder machine frame design to make sewing operation easier for circular cloth. Easy maintenance and adjustment.



全自動加油系統，潤滑各部零件，提升機台壽命

Automatic oiling system to lubricate all spare parts, to extend the machine lifetime.



密閉式針杆及天秤結構，防止漏油

Entirely sealed needle bar and take-up design to prevent oil leakage.



按鈕式縫距調整裝置，簡便省時，減少一般式調整或更換零件之冗長作業

Stitch length adjustment by knob, saves time for adjustment and maintenance.

可更換不同規格元件，適合多樣的鋸齒飾邊或雙鋸齒飾邊

Different gauge set can be easily changed suitable for various picot sewing.

**Z1**

Z008-248Q	2	4	3.7~7.4	1	7	UO163 #11	3500
-----------	---	---	---------	---	---	-----------	------

## Z型裝飾

適用於女用內衣褲、手絹、桌布、禮服、童裝、運動裝、枕套等之各種裝飾縫。

## ZIGZAG SEWING

Suitable for making decorative zigzag stitches on women's underwears, handkerchiefs, tablecloths, formal dresses, children's wear, sportwears and pillowcases.



# DEVICE



## DV<sup>1</sup><sup>2</sup> 下軸型直驅伺服馬達 Lower main shaft type Direct drive servo motor

多針鏈縫機模組化搭配直驅伺服馬達，多樣化的選擇，更有彈性。

<sup>1</sup> = 廠商代碼 <sup>2</sup> = 版本代碼 + 功能代碼

Double chainstitch machine equipped with the modularized direct drive servo motors to be more flexible for diversification.

<sup>1</sup> = Manufacturer code <sup>2</sup> = Version code + Function code

可自行組裝 self-installation : YES

適用機型 applicable model : 全系列多針鏈縫機 All Double Chainstitch Series

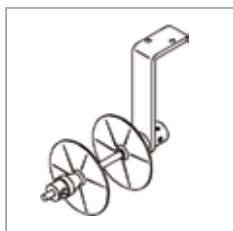

## FH 下固定式送帶盤 Lower Fixed Tape Holder

置於桌下方放布條或鬆緊帶。

Holds tape or elastic tape under the table

可自行組裝 self-installation : YES

適用機型 applicable model : VC008A/VWL, VC008A/VWLB, VC008A/VWLC, HF008A/HPR



## JD 跳針裝置 Skip Stitch Device

避開褲腰車縫時不需下針的地方。

Control freely to avoid stitches sewed on un-wanted working area.

可自行組裝 self-installation : NO

適用機型 applicable model : HF008A, NC008



## LSA 上固定式送帶盤 Upper Fixed Tape Holder

置於上前方放布條或鬆緊帶。

Holds tape or elastic tape in front.

可自行組裝 self-installation : YES

適用機型 applicable model : VC008(A/B)/VPL



## RL 筒型衣物撐開滾輪組 Tubular Extending Roller

協助將筒型衣物撐開，便於車縫。

Extends the tubular material to make sewing process easier.

可自行組裝 self-installation : YES

適用機型 applicable model : VC008(A/B)/VCE



## VAD

### 氣壓式抬壓腳裝置 Pneumatic Presser Foot Lifter

利用氣壓提升壓具可提高效率。

註: 1. 需有空壓設備 2. 搭配伺服馬達使用

Pneumatic presser foot lifter is used to improve operation efficiency.

Remark: 1. Compressor capability needed. 2. Servo motor needed.

可自行組裝 self-installation : YES

適用機型 applicable model : VC008A, VC008B



## VAR

### 密縫裝置 Condense Stitching Device

於車縫起始或結束時進行密縫的功能，確保縫線不易脫落，提高車縫品質。

Reinforce the stitches at the beginning and end of sewing, to enhance sewing sturdiness and quality.

可自行組裝 self-installation : NO

適用機型 applicable model : VC008A, VC008B



## VCE

### 環型褲頭鬆緊帶上帶裝置 Tubular Elastic Inserting and Attaching

用於運動褲或男內褲等圓筒型衣褲上鬆緊帶包縫，本機型可有兩種縫合方式:

1. 環型鬆緊帶布料折邊縫。
2. 拷克後上環型鬆緊帶包縫。

Tubular elastic inserting on sportswears or man's underwears, two types of sewing functions are available:

1. To attach tubular seamless elastic waistband.
2. To cover sewing on elastic after overlock seaming.

可自行組裝 self-installation : YES

適用機型 applicable model : VC008A, VC008B



## VCL(P)

### 後拉引滾輪 Rear Puller

協助車縫後平順，不會擠壓。與針位距離 72 mm，讓拉布與出布更穩定。

註: 各機型搭配平輪或齒輪如下表，若有異於標準品訂購時請特別註明。

Smooths the sewing process, and no shirr. The 72 mm distance from the needle helps to stabilize the fabric during sewing process.

Remark: Please check the type of pullers (flat or serrated) used for different machines from the table below. If you would like to order different pullers standard, please remark when ordering other than.

滾輪 / Roller	平輪 / Flat	齒輪 / Gear
上 / Upper	VCL16P	VCL37P(27T)
下 / Lower	VCL28	VCL33P(16T)
VC008(A/B)-04xxxP		S
VC008(A/B)-04xxxP/VCE		S
VC008A-04Axx-xxxP/VSF	S	
VC008A-04xxxP/WWL		S
VC008(A/B)-06xxxP/VPL	S	
VC008A-12xxxP		S
VC008(A/B)-04xxxP/VCE		S
VC008A-12xxxP/VPQ	S	
VC008A-12xxxP/WLC		S
VC008A-12xxxP/VPQ-K	S	

### 滾輪選用原則 Puller Set Application

平輪 Flat type	塑膠 PU	適用一般薄布料·如梭織棉布 For common materials, eg: woven cotton fabric.
	橡膠 Rubber	適用貼帶車縫·或光滑薄布料使用·如梭織絲光布 For tap attaching or slippery materials, eg: woven silk fabric.
齒輪 Gear type	粗齒塑鋼 Big-teeth POM	適用鬆緊帶車縫 For elastic band sewing
壓花輪 Knurling type	鋼質 Steel	適用牛仔類與厚布料 For jeans and heavy material

可自行組裝 self-installation : NO

適用機型 applicable model : VC008A, VC008B

### VCL滾輪明細表 VCL Roller List

Type	平輪 Flat Type				齒輪 Gear Type		壓花 Knurling	
	硬質塑膠 PU (Black)		軟質橡膠 Rubber (Black)		塑鋼 POM (White)		鋼質 Steel	
長度 Length	56mm	80mm	56mm	80mm	56mm	80mm	56mm	78mm
上滾輪 Upper	VCL16	VCL18P	VCL16Q	VCL16R	VCL08 (22T) 厚 Heavy	VCL08P (22T) 厚 Heavy	VCL08Q	VCL08N
					VCL37 (27T) 中厚 Medium	VCL37P (27T) 中厚 Medium		
下滾輪 Lower	VCL28		VCL28R		VCL33 (14T) 厚 Heavy		VCN33N	
					VCL33P (16T) 中厚 Medium			
					VCL61 (28T) 薄 Light			
					VCL64 (32T) 輕薄 Fine			



## VPQ

### 彈性線抽折縫裝置 Elastic Thread Shirring

適用於女用裙皺褶·連身衣裙等腰邊鬆緊帶皺褶均能順暢縫紉·勾針底線宜用彈性線。  
Suitable for sewing ornamental shirring on women's blouses. Suggested to use elastic thread for lower looper.

可自行組裝 self-installation : YES

適用機型 applicable model : VC008A-12048P, VC008A-12064P



## VPQ-K

### 彈性線抽折縫裝置 Elastic Thread Shirring

適用於女用裙皺褶·連身衣裙等腰邊鬆緊帶皺褶均能順暢縫紉。

1. 勾針底線宜用彈性線。
2. 增加VWL組可穩定鬆緊帶的鬆緊度讓車縫更平順美觀·不跳針。
3. 將彈性線安裝於桌板下·讓彈性線車縫更順暢。
4. 本配件為多功能·可調為VWL·VPQ單一使用。

Suitable for sewing ornamental shirring on women's blouses.

1. Suggested to use elastic thread for lower looper.
2. The added VWL set will further stabilize the tension of elastic thread and make sewing process more smoothly, also can avoid stitch skipping.
3. Holds the elastic thread under the table to make sewing process more smoothly.
4. Multifunction device can be adjusted to VWL or VPQ.

可自行組裝 self-installation : YES

適用機型 applicable model : VC008A-12048P, VC008A-12064P



## VPL

### 貼帶裝置 Tape Attaching

主要用於襯衫門襟·腰帶·運動衣等裝飾條帶。

註: 1.喇叭成品規格如圖表。

2.布條之尺寸可依3/16"或1/4"倍數變換。

Decorative tape for shirt-fronting, sportswears, waist band, etc...

Remark: 1. Folder and finished goods specifications as listed in the table below

2. Tape size can be adjusted in multiples of 3/16" or 1/4".

機型 Model	完成尺寸 Finished Size(mm)	X	Y	Z	針距 Needle Gauge	壓具 Presser Foot
VC008(A/B)- 06048P	8	B417P	B417AP	B417P	3/16"	P9412DA
	9	B417Q	B417AQ	B417Q		P9412D
VC008(A/B)- 06064P	10	B417R	B417AR	B417R	1/4"	P9512DA
	12	B417S	B417AS	B417S		P9512D
	16	B417U	B417AU	B417U	1/2"	P9512B

可自行組裝 self-installation : YES

適用機型 applicable model : VC008(A/B)-06048P, VC008(A/B)-06064P



## VPS

### 彈性線抽折縫裝置 Elastic Thread Shirring

適用於女用裙皺褶·連身衣裙等腰邊鬆緊帶皺褶·如:女襯衫·游泳衣·婦女用衣物·枕頭套·兒童衫。針線用彈性線·勾針為勾線功能不穿線·為101車縫式樣。

Suitable for sewing ornamental shirring on women's blouses, swimsuits, pillowcases, children's shirts. Needle uses elastic thread and looper without any thread. It's 101 sewing type.

可自行組裝 self-installation : YES

適用機型 applicable model : VC008A-12048P, VC008A-12064P



## VWL VWLB VWLC

### 前鬆緊帶送帶滾輪裝置 Front Elastic Feeding

鬆緊帶送帶滾輪裝置能隨機台本身之運轉·將鬆緊帶送出·且可調整鬆緊帶送出量之多寡·操作簡便;車縫慢跑褲·運動褲·休閒褲等褲頭·由於前後導輪裝置·上鬆緊帶時能保持一定張力·維持車縫品質。

註:VWL 附 B413 喇叭

VWLB 附 B411喇叭及撐開滾輪組

VWLC 附 VCE 導片

Length of elastic type can be easily adjusted by elastic feeding device, suitable for sports pants and casual pants. Roller maintains the tension of elastic thread and quality during sewing process.

REMARK: VWL with folder B413

VWLB with folder B411 and extending roller

VWLC with VCE fabric guide

可自行組裝 self-installation : YES

適用機型 applicable model : VC008A-04064P, VC008A-04085P, VC008A-04095P,  
VC008A-04106P, VC008A-04127P, VC008A-12048P,  
VC008A-12064P

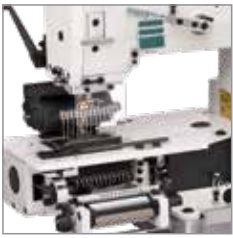

## VSC

### 鬆緊帶抽皺縫裝置 Elastic Thread Shirring Sewing

彈性線直送不打線圈·由針線與勾針線上下包覆·車縫成品效果較VPQ薄·且皺褶可拉伸至完全平坦。

Elastic thread is straight, not looped, which is fixed by needle thread and looper thread. The finish is thinner than VPQ and the shirring becomes flat as it is pulled extensively.

可自行組裝 self-installation : NO

適用機型 applicable model : VC008A-12048P, VC008A-12064P



## VUT

### 自動切線裝置 Pneumatic Automatic Thread Trimmer

氣動式自動切線可提高車縫效率節省成本。

Pneumatic automatic thread trimmer increases operation efficiency and saves the cost.

可自行組裝 self-installation : NO

適用機型 applicable model : VC008(A/B)-04085P, VC008(A/B)-12048P, VC008(A/B)-12050P, VC008(A/B)-12064P



## VC008 彈性線機型對照/ VC008 Comparison on Elastic Thread Models

型號 Model	布樣 Sample Fabric	面線(針線) Surface Thread (Needle Thread)	底線(勾針線) Rear Thread (Looper Thread)	花樣線 Decorative Thread	備註 Remark
VPQ		一般 Standard	彈性線 Elastic	-	
VPQK		一般 Standard	彈性線 Elastic	-	車縫與VPQ完全相同 差別在多加VWL下送輪, 使底線控線穩定 Same stitch as VPQ. The difference is on the front roller, VWL, which stabilizes rear thread controls.
VPS		彈性線 Elastic	無 None	-	勾針不穿線 Looper without thread.
VSC		一般 Standard	一般 Standard	-	彈性線拉直,由底線與面線包 Elastic thread is stretched and covered by rear thread and surface thread.

# TABLE

桌板代號 Item No.	尺寸 / Size (mm)			說明 Description	適用機型 Applicable Model	備註 Remark
	長 Length	寬 Width	厚 Thickness			
VC008-T1	1200	540	45	半沉式 Semi-submerged	VC008(A/B)-04 VC008(A/B)-04P/VCE, VUT	開口型 Open type
VC008-T2	1200	540	45	上乘式 Non-submerged		
VC008-T3	1200	540	45	半沉式 Semi-submerged	VCO08B-11, VCO08B(A/B)-12, VCO08A-13, VCO08(A/B)-06/VPL, VC008A-12/VPQ, VCO08(A/B)-12/VUT	開口型 Open type
VC008-T4	1200	540	45	上乘式 Non-submerged		
VC008-T5	1200	540	45	半沉式 Semi-submerged	VC008A-04/VWL, VWLB, VWLC	
VC008-T6	1200	540	45	半沉式 Semi-submerged	VC008A-12/VPQK, VWL	
VC008-T9	1200	540	45	半沉式 Semi-submerged	VC008A-12/VSC	
VC008-T10	1200	540	45	全沉式 Full-submerged	VC008(A/B)-04, VC008A-12	需搭配 SM899-A SM899-A set required
VC008-T25	1200	600	45	上乘式 Non-submerged	VC008(A/B) for SLA	
HF008-T1	1200	540	45	半沉式 Semi-submerged	HF008(A)	
HF008-T3	1200	540	45	全沉式 Full-submerged	HF008(A)	
HF008-T4	1200	540	45	半沉式 Semi-submerged	HF008(A)/FBQ	
Z008-T1	1200	540	45	半沉式 Semi-submerged	Z008	
Z008-T2	1200	540	45	上乘式 Non-submerged	Z008	開口型 Open type
NC008-T1	1200	600	45	上乘式 Non-submerged	NC008	開口型 Open type